

## Multijet Water Meter

CWMU



### Key Features

- Cold (30°C) - MID Approved, R80
- WRAS Approved
- Super Dry, Sealed Register
- Suitable up to 16 Bar Working Pressure
- Internal Strainer
- Pulsed Output as Standard



Part Number	Size (mm)	Nominal Flow Q3	Min Flow Q1	Max Flow Q4	Pulse Value L/P
C/H-WMU15	15	2.5 m <sup>3</sup> /hr	0.031 m <sup>3</sup> /hr	3.13 m <sup>3</sup> /hr	10
C/H-WMU20	20	4.0 m <sup>3</sup> /hr	0.050 m <sup>3</sup> /hr	5.00 m <sup>3</sup> /hr	10
C/H-WMU25	25	6.3 m <sup>3</sup> /hr	0.078 m <sup>3</sup> /hr	7.88m <sup>3</sup> /hr	10
C/H-WMU32	32	10.0 m <sup>3</sup> /hr	0.125 m <sup>3</sup> /hr	12.5m <sup>3</sup> /hr	10
C/H-WMU40	40	16.0 m <sup>3</sup> /hr	0.200 m <sup>3</sup> /hr	20.0m <sup>3</sup> /hr	100
C/H-WMU50	50	25.0 m <sup>3</sup> /hr	0.313 m <sup>3</sup> /hr	31.3m <sup>3</sup> /hr	100

\*C for Cold Versions and H for Hot Versions

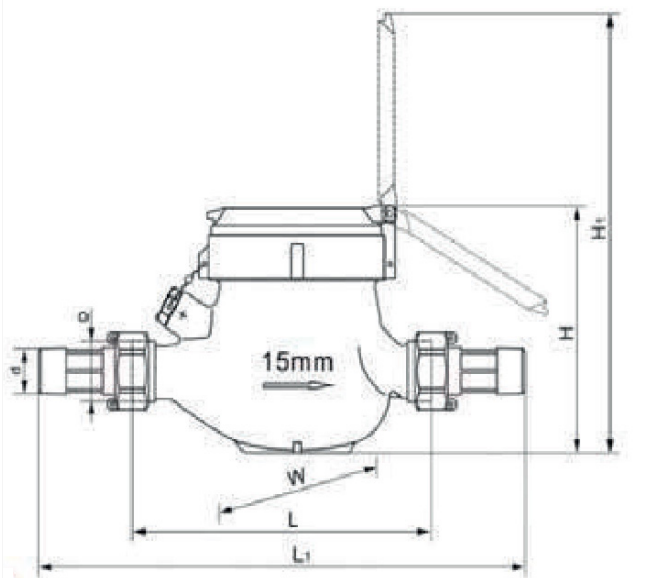

Size	L	L1	D	d	H	H1	W
15	165	259	G3/4B	R1/2	107.5	191	94
20	190	294	G1B	R3/4	107.5	191	94
25	260	380	G1 1/4B	R1	117.5	206.5	98
32	260	384	G1 1/2B	R1 1/4	117.5	206.5	98
40	300	431	G2B	R1 1/2	141.5	256.5	122
50	300	448	G2 1/2B	R2	177	292	145

## INSTALLATION GUIDELINES FOR MULTI JET WATER METERS

### Sizing and Selection:

- Maximum flow is only for use in emergencies, for about 1-2 minutes as it causes the bearings to overheat.
- Minimum flow only refers to the minimum flow required to operate and record on the meter. At these very low flows, the meter will not be accurate.
- All water meters should be sized between transitional flow (the point at which the meter is most accurate) and nominal flow (permanent flow rate).
- The meters are designed only for use with clean water. Sufficient filtration prior to the meter should be considered if the quality of water is compromised.

### Installation:

- The preferred mounting position is horizontal. Installing meters in vertical pipe is possible – this will in effect reduce the accuracy of the meter by one accuracy class. Ensuring that the flow rate is double the  $Q_t$  value can reduce the meter error.
- Under no circumstances whatsoever must the meters remain in situ whilst system flushing takes place.
- Water meters should always be fitted with a minimum of 5x pipe diameter both up and downstream. For example, a 2" (DN50) water meter would have 10" (250mm) either side of the meter as straight pipe. This is to ensure accurate reading by reducing water turbulence. At higher pressures (above 8 bar), this should be increased to 10x pipe diameter.
- Note that there is a direction of flow arrow on the meter and the meter should be installed accordingly.
- It is recommended as good practice to fit a removable filter element before a water meter to protect the mechanism.
- Only clean water should be used that does not exceed the temperature specification of the meter. This is 30 degrees centigrade for cold meters and 90 degrees centigrade for hot meters.

